

# **MINN KOTA**

---

## **TURBO**

OWNER'S INSTRUCTION MANUAL



### **MODEL 35T Turbo**

Congratulations  
...for selecting the most popular  
electric fishing motor in America.

#### **CAUTION:**

READ MANUAL CAREFULLY BEFORE  
OPERATING YOUR NEW MINN KOTA  
ELECTRIC FISHING MOTOR. RETAIN  
MANUAL FOR FUTURE REFERENCE.

---

Specifications & Features .....	p. 2	Replacement Parts .....	F
Operation .....	p. 3	Wiring Diagram .....	F
Battery Information & Propeller Replacement ..	p. 4	Parts Diagram .....	F
Trouble Shooting & Maintenance .....	p. 5	Warranty .....	F

# SPECIFICATIONS

Model 35 Turbo	
Motor	3 1/4" Diameter, Double Sealed, Permanent Magnet
Voltage	12
Thrust*	24 lbs.
Maximum Ampere Draw*	24
Maximum Propeller Speed	950 RPM
Propeller Diameter	9 inches
Tube Length	30-36 inches
Tilt Positions	10

\* Thrust rating is established by tank testing with an electronic tension transducer. Tests are run with voltage equal to that of a fully charged deep cycle battery (12.8 VDC) applied to the motor brushes. Maximum amp draw is measured in actual on-the-water use.

# FEATURE INFORMATION

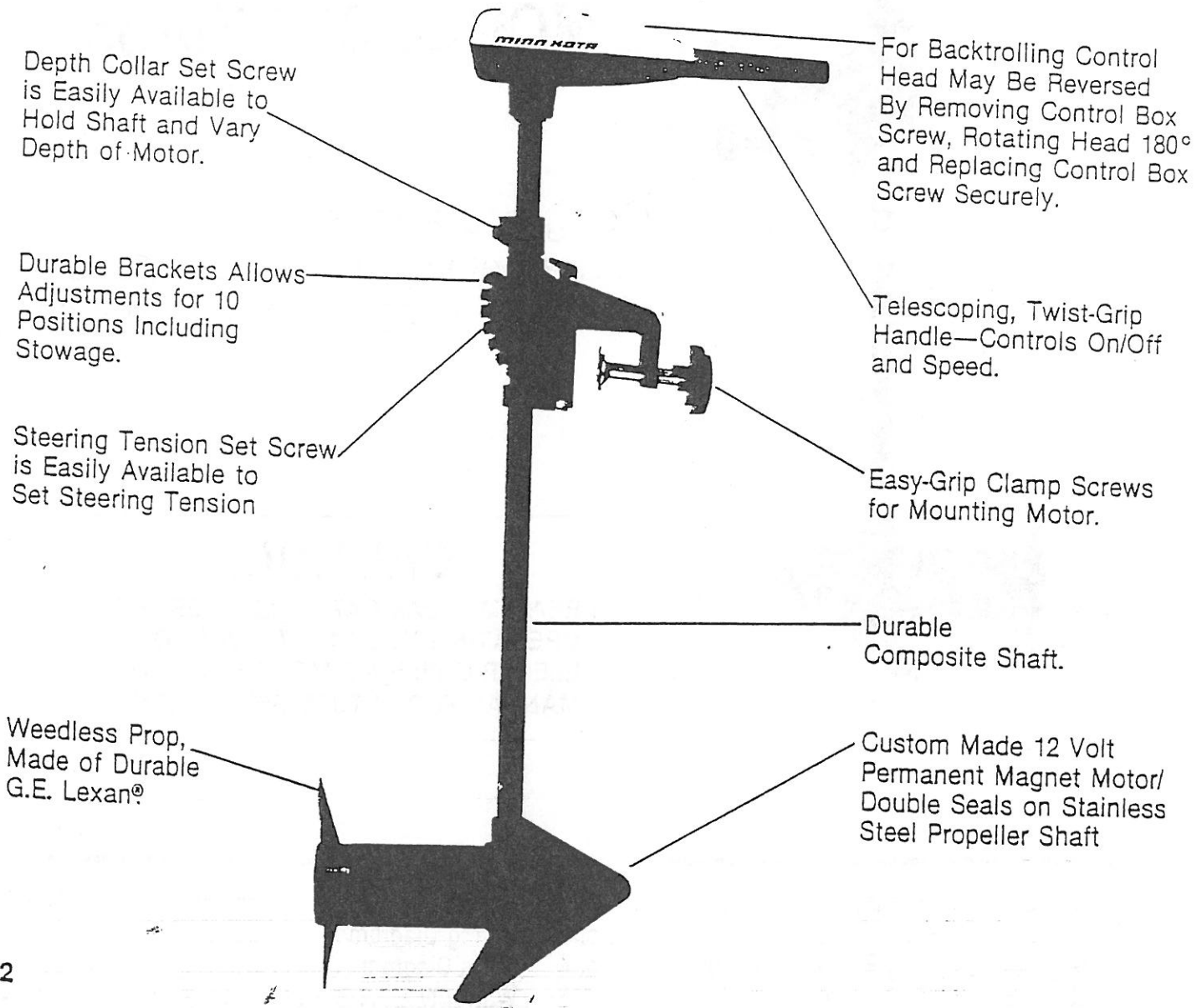

## OPERATION

**MOUNTING ON THE BOAT:** Numbers in diagram refer to parts list on page 6.

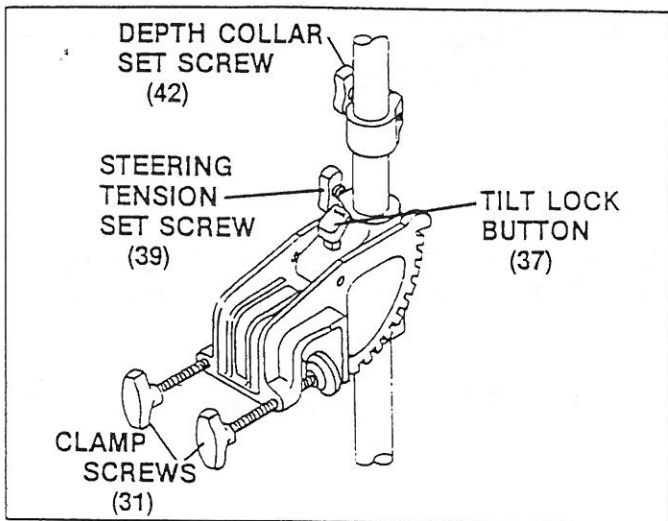

**CAUTION:** Never operate your Minn Kota motor when it is out of the water.

Mount your motor on the transom, bow or either side of the boat, then tighten the clamp screws (31) securely.

To adjust the depth, loosen the steering tension set screw (39) and turn the depth collar set screw (42) until the tube slides freely. Raise or lower the motor to the desired depth and tighten the depth collar set screw. The steering tension set screw may be adjusted to your preference as you use your motor. **In setting the depth, be sure the top of the motor is submerged at least 6 inches to avoid agitation and churning of the surface water. The propeller should always be completely submerged.**

To adjust the tilt simply depress and hold the tilt lock button (31), tilt to any of 10 positions on the mounting bracket, then release the button.

You can set your motor in a vertical position, angle it for shallow water, or tilt it completely out of the water when not in use.

**CAUTION:** When adjusting the tilt on your motor, keep fingers free from area between shaft and bracket.

**Adjust your steering tension** using the steering tension set screw (39) to provide enough tension to allow the motor to turn freely, yet remain in any position without being held. It can also be used to lock the motor in a preset condition, to leave your hands free for fishing while trolling or positioning the boat.

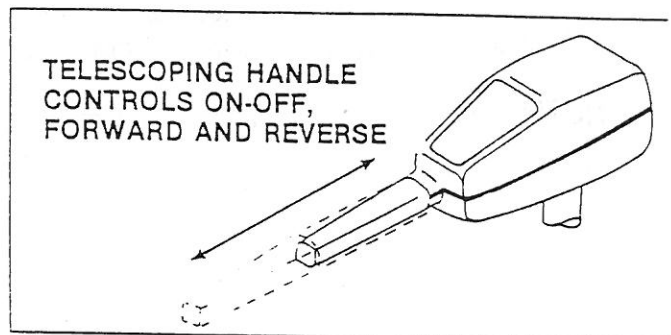

Select forward or reverse and your speed by turning your steering grip to any of the speed positions indicated on the twist grip handle.

**Adjust your steering handle length.** A telescoping handle allows you to easily extend its length for the most comfortable "reach" from your seat. To extend handle, simply pull it towards you to any of the "click-stops."

## BATTERY INFORMATION

---

Your motor will operate with any 12 volt battery. For best results use a battery with at least an 80 ampere hour rating. Maintain battery at full charge. Use a variable rate charger to avoid overcharging the batteries. If you are using a battery to start a gasoline outboard, we recommend that you use a separate deep cycle battery for your Minn Kota motor.

### BATTERY CONNECTION

**CAUTION:** Before connecting batteries, make sure the twist-grip handle is in the "O" position. Connect the positive (+) red lead to the positive (+) battery terminal. Negative (-) black lead to the negative (-) battery terminal. See wiring diagram on page 6.

**NOTE:** It is recommended that your motor be disconnected when not in use for extended periods.

## PROPELLER REPLACEMENT

---

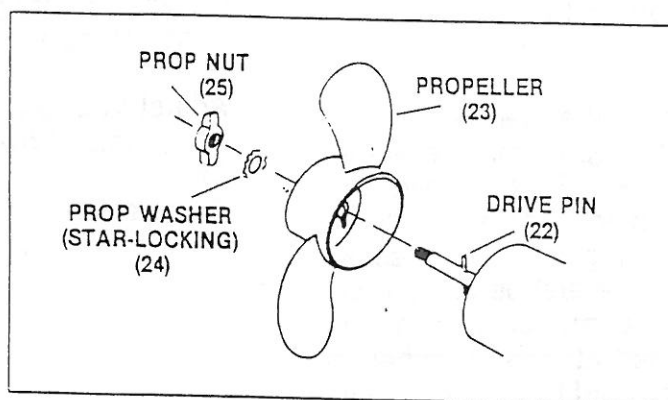

**CAUTION:** Be sure motor is disconnected from battery.

Hold prop blade and loosen prop nut (25) with pliers. Remove prop nut. Pull straight off. Align new prop (23) with drive pin (22). Install prop washer (24) (star-locking) and prop nut. Tighten prop nut  $\frac{1}{4}$  turn past snug.

**NOTE:** If you experience excessive vibration while operating your motor in reverse speeds—remove the prop nut and prop washer. Pull out on the propeller until the propeller is disengaged from the drive pin. Rotate the propeller  $180^\circ$  on the shaft and engage propeller to drive pin. Replace prop washer and prop nut. Tighten propeller nut  $\frac{1}{4}$  turn past snug.

## **TROUBLE SHOOTING**

---

### **1. Motor fails to run or lacks power**

- Check battery connections. Be sure terminals are clean and corrosion free. Use a fine grade of sand paper or emery cloth to clean terminals.
- Check your battery's water level. Add water if needed.
- Check propeller for line or weeds.
- If connections are good and your battery has a full charge, obtain service as instructed.

### **2. Motor loses power after a short period of time**

- Have your battery checked or charged.

### **3. Motor is hard to steer.**

- Loosen the steering tension set screw at the rear of the bracket.

FOR ALL OTHER MALFUNCTIONS, SEE  
ENCLOSED AUTHORIZED SERVICE CENTER  
LISTING FOR NEAREST SERVICE CENTER.

## **MAINTENANCE**

---

1. The composite shaft requires periodic cleaning and lubrication to insure smooth retraction and deployment. A coating of Kit Luster Rich® or Armorall® works well and will provide 'like new' operation.

2. After use—particularly in salt or brackish water—it is recommended to rinse unit with fresh water and wipe down unit with damp cloth using a silicone spray or light oil, coat metal parts if prolonged storage will occur.

# MODEL 35 Turbo

## REPLACEMENT PARTS

Replacement parts may be ordered from Parts Department, Minn Kota, Johnson Fishing, Inc., 1531 Madison Ave., Mankato, Minnesota 56001, or in Canada, see our Authorized Service Center List. Be sure to specify the model number and serial number of your motor and the part number(s) as shown on the following list. Minimum charge \$3.00. Payment may be by cash, check, MasterCard or VISA card. Please add \$3.00 for postage and handling on all orders.

Item No.	Part No.	Description	Item No.	Part No.	Description	Item No.	Part No.	Description
1	406-022	Front End Bell	24	205-1700	Lock Washer	38	203-1830	Hinge
2	403-244	Speed Coil Assembly	25	205-3100	Prop Nut	39	201-1385	Tension Screw
3	406-402	Brush Plate Assembly	26	203-9060	Motor Assembly Complete	40	203-2800	Tension Block
4	406-081	Brush Spring (2 req'd.)	26A	206-6641	Motor Decal (2 req'd.)	41	203-1520	Collar
5	406-070	Brush Assembly (2 req'd.)	28	203-2051	Tube (30")	42	201-1365	Screw-Collar
6	406-341	Brush Plate Screw (2 req'd.)	28A	203-2052	Tube (36") (optional)	43	202-0600	Leadwire
7	406-090	Brush Holder	28B	203-2053	Tube (42") (optional)	44	206-2540	Control Box
8	403-205	Armature Assembly	28C	203-2054	Tube (48") (optional)	44A	206-6645	Decal Control Box (2 req'd.)
9	405-300	E-Ring	29	299-1800	Hinge & Bracket Assembly (Includes 29A, 30, 34-39)	45	206-6930	Gasket
11	406-170	Thrust Washer-Steel	29A	277-1907	Bracket Assembly (Includes 29B, 31-33)	46	206-0231	Control Box Cover
12	405-171	Thrust Washer-Nylatron	29B	203-1910	Bracket (Not available separately)	47	203-5680	Decal-Cover
13	406-480	Gasket	30	201-0511	Hinge Pin	48	203-4020	Switch
14	403-253	Center Section w/magnets	31	201-1375	Clamp Screw (2 req'd.)	49	202-0310	Connecting Wire
15	406-460	O-Ring	32	201-1710	Clamp Washer (2 req'd.)	50	203-3400	Screw
16	406-600	Flange Bearing	33	201-3010	Retaining Ring (2 req'd.)	51	201-3110	Nut
17	406-032	Rear End Bell	34	203-3602	T-Bar	52	201-2100	Screw (6 req'd.)
18	406-461	Seal	35	201-2700	T-Bar Spring	53	203-0991	Handle Assembly
19	406-471	Seal (cup)	36	201-3000	E-Ring	55	201-0030	Bearing-Handle Cap
20	401-462	O-Ring Thru Bolt (2 req'd.)	37	201-0110	Tilt Knob	56	201-0011	Handle Bearing-Outer
21	403-352	Thru Bolt (2 req'd.)				57	201-0000	Handle Bearing-Inner
22	209-2600	Drive Pin				58	201-0700	Battery Clips
23	203-1160	Propeller						

## WIRING DIAGRAM

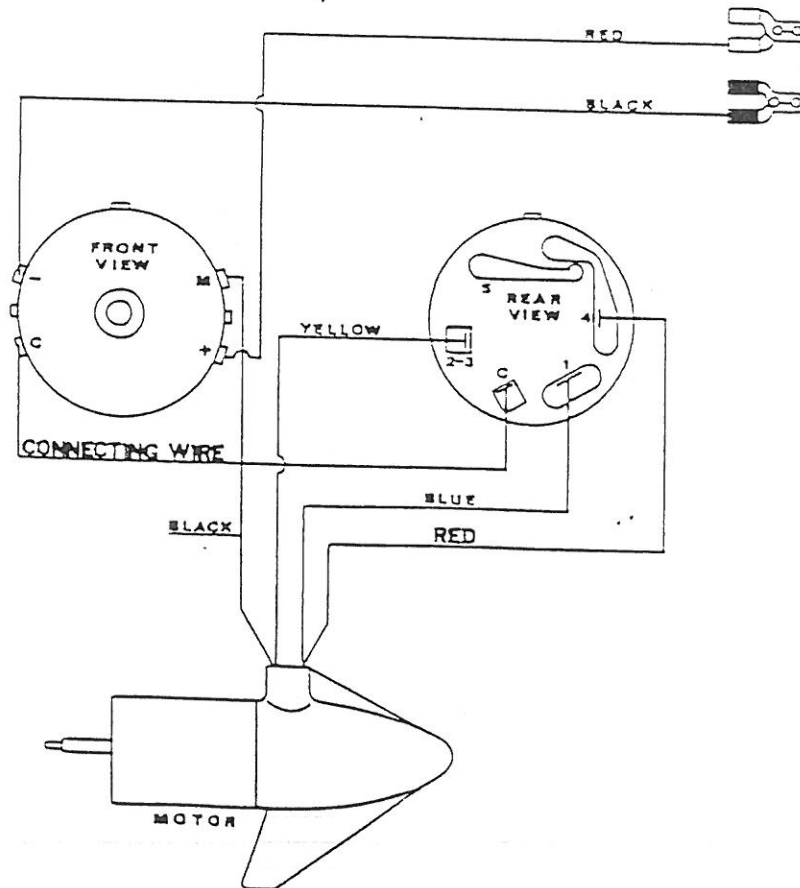

# PARTS DIAGRAM

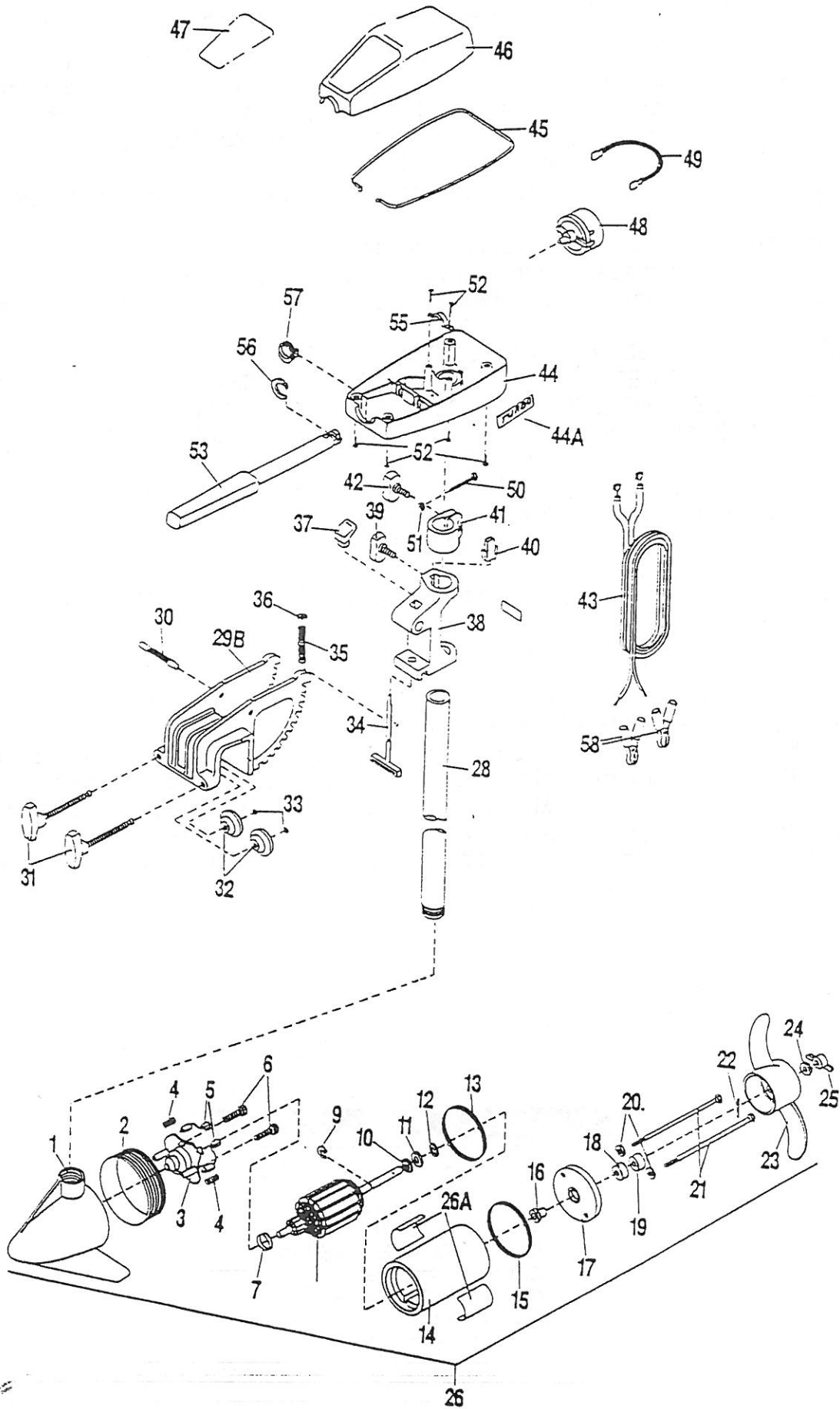

## LIMITED WARRANTY

---

Minn Kota, Inc. warrants to the original purchaser that its Electric Trolling Motors are free from defects in materials or workmanship for a period of one (1) year from the date of purchase, except that this warranty shall not apply to any Motors used commercially. The Motor must be returned, prepaid and with proof of the date of purchase, to Minn Kota, Inc., 1531 Madison Avenue, Mankato, Minnesota 56001 or to any authorized Minn Kota service center listed on the attached sheet. Defective parts only must be returned to Minn Kota, Inc. with proof of purchase date for warranty consideration or replacement.

If, after inspection, we find that the product or part was defective in material or workmanship, we shall, at our option, either repair or replace it without charge. We are not responsible for normal wear and tear or for defects caused by accidents, abuse, alteration, modification, misuse or improper care.

THERE ARE NO OTHER EXPRESS WARRANTIES BEYOND THE TERMS OF THIS LIMITED WARRANTY. IN NO EVENT SHALL ANY IMPLIED WARRANTIES, INCLUDING MERCHANTABILITY AND FITNESS FOR A PARTICULAR PURPOSE, EXTEND BEYOND THE DURATION OF THE EXPRESS WARRANTY CONTAINED HEREIN. IN NO EVENT SHALL MINN KOTA, INC. BE LIABLE FOR INCIDENTAL OR CONSEQUENTIAL DAMAGES.

Some states do not allow limitations on how long an implied warranty lasts or the exclusion or limitation of incidental or consequential damages, so the above limitations or exclusions may not apply to you.

This warranty gives you specific legal rights, and you may also have other rights which vary from state to state.

### QUALITY PRODUCTS DESERVE QUALITY SERVICE

At Johnson Fishing we're just as concerned about providing quality service as we are about providing quality products. That's why our motors are backed by a full one year limited warranty from the date of purchase. If for some reason, your new Minn Kota should require service you can be assured that the problem will be corrected to your satisfaction by one of our many Authorized Warranty repair facilities or the Customer Service Department at Johnson Fishing. After all—"quality products deserve quality service".

**MINN KOTA**  
ELECTRIC FISHING MOTORS

1531 MADISON AVENUE  
MANKATO, MINNESOTA 56001  
PARTS, SERVICE WARRANTY:  
CALL 507-345-4659  
OR CALL TOLL FREE:  
1-800-227-6433  
FAX NO. (507) 345-4936