

40AT/H
40 lbs Thrust
12 Volt 42 Amp
42" Shaft

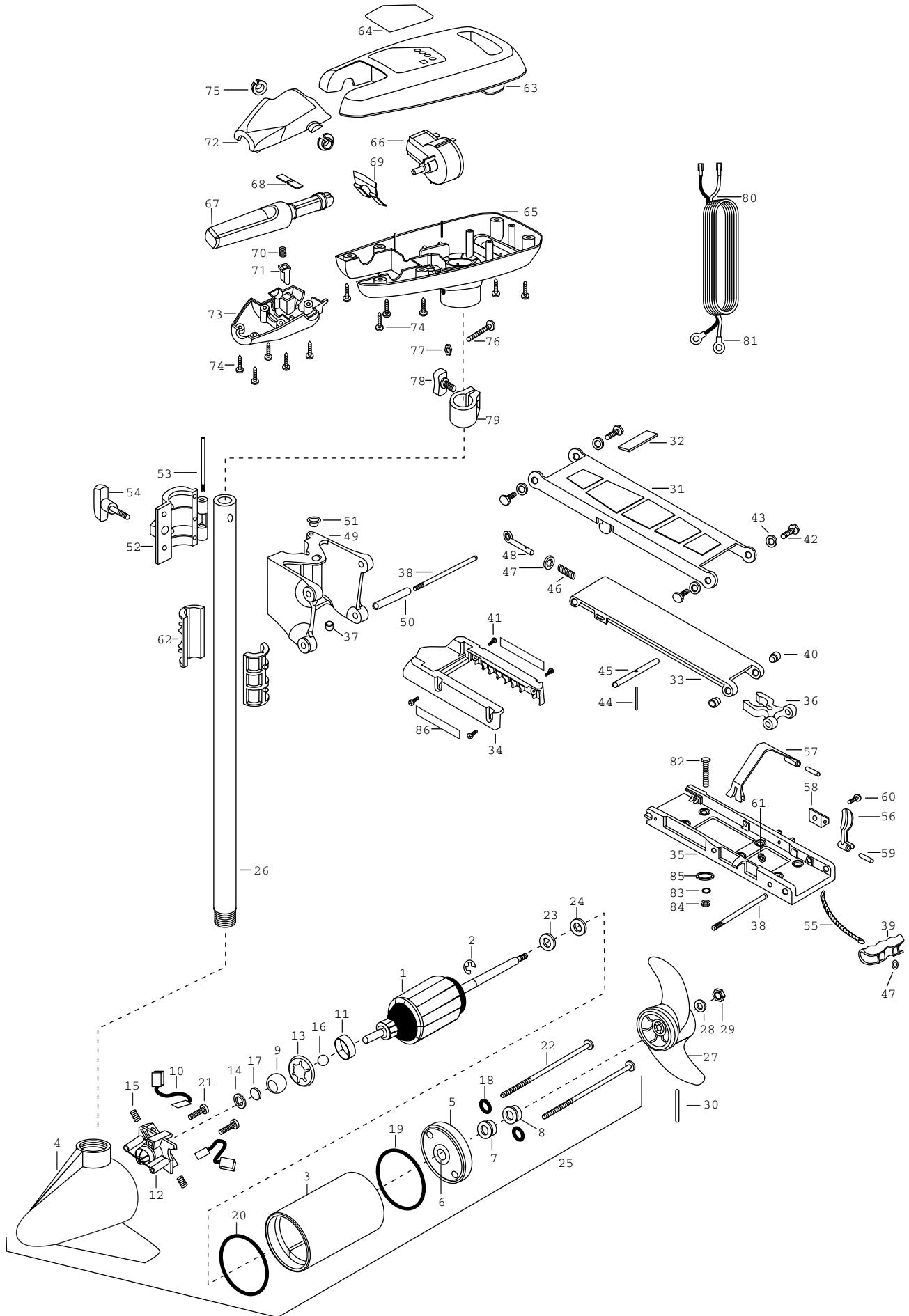

1	2-100-001	ARM ASSEMBLY 12V 3.25 FW 40#	■	2771970	STD-BOWMT FW H/CTRL ASSEMBLY	60	2263440	SCREW-10-24 X 3/4	
2	788-015	RETAINING RING		31	2264221	ARM-UPPER, STD, FW	61	2333101	NUT-HEX 3HP-SS NYLOC
3	431-079	HOUSING ASSEMBLY CENTER 3.25 TXT		32	2265120	BUMPER UPPER ARM	62	2151532	HINGE-SLEEVE HALF-AT [2.EA]
4	2-300-132	HOUSING ASSEMBLY BRUSH END 3.25 SPCO	■	2774310	ARM-LOWER ASSEMBLY FW	63	2060283	COVER-CONTROL BOX AT/H BLK	
5	2-400-127	PLAIN END HOUSING ASSEMBLY			INCL. 33,44,45,46,47,48,39,55	64	2185606	DECAL-COVER 40AT/HC	
6	144-049	BEARING - FLANGE [SERVICE ONLY]		33	2254352	ARM-LWR FW	65	2062551	CONTROL BOX PLAS W/HAND
7	880-003	**SEAL		34	2263900	MOTOR REST A/T	66	2064023	SWITCH-FWD/REV 5SP
8	880-006	**SEAL WITH SHIELD		35	2251922	BOW PLATE-D/C	67	2990912	HANDLE ASSEMBLY-W/U-JOINT 5SP
9	144-050	BEARING - SPHERICAL		36	2293801	TUBE LOCK-'D'	68	2302742	SPRING-DETENT OFF
10	188-052	BRUSH ASSEMBLY [2.EA]		37	2264705	INSERT-HINGE BASE (STD MT)	69	2302743	SPRING-DETENT HANDLE-TILT
11	725-033	BRUSH RETENTION- PAPER TUBE		38	2260506	HINGE-PIN (HEADLESS) ZINC [2.EA]	70	2302745	SPRING-RELEASE BUTTON
12	738-031	BRUSH PLATE W/HOLDER 3.25 ASSEMBLY INCLUDES 14,17,18		39	2150400	PULL-GRIP	71	2303720	RELEASE BUTTON-HANDLE
13	784-036	BEARING RETAINER		40	2236000	BEARING NYLINER- [2.EA]	72	2060408	HANDLE- TOP HALF
14	991-025	WASHER - FELT		41	2303431	SCREW 1/4-20X5/8'PPH [4.EA]	73	2060415	HANDLE- LOWER HALF
15	975-032	SPRING - COMPRESSION [2. EA]		42	2293511	BOLT-UPPER ARM W/LOCTITE [4.EA]	74	2303412	SCREW-6-20 X 5/8 SELF TAP [11.EA]
16	116-020	BALL - STEEL		43	2293500	BUSHING-SHOULDER UPR ARM [4.EA]	75	2060005	BEARING-HANDLE PIVOT [2.EA]
17	303-039	THRUST DISC - METAL		44	2152610	SPRING-PIN LOCKBAR	76	2033400	SCREW-10-24 X 1-3/4
18	701-007	**O-RING [2. EA]		45	2233600	LOCK BAR- BOW MOUNT	77	2013110	NUT-10-24 HEX (ZCP)
19	701-039	**O-RING MK406460		46	2152700	SPRING- LOCKBAR CAD.PLTH	78	2011365	SCREW-COLLAR/NEW KNOB
20	701-041	**O-RING		47	2151700	WASHER-EYE SHAFT .562 OD [2.EA]	79	2031520	COLLAR-DEPTH W/O INSERT
21	830-001	SCREW - #8-32X1.75 SELF-THRE [2.EA]		48	2153600	EYE SHAFT-CAD.PLATE	80	2090600	LEADWIRE -10 GA RINGS
22	830-078	THRU BOLT 8-32 X 8.96 [2. EA]		49	2261811	HINGE BASE-F/W	81	2020700	TERMINAL RING, 3/8' [2.EA]
23	990-067	WASHER - STEEL THRUST		50	2231570	SLEEVE ROLLER- HINGE BRACKET	■	2994837	BAG ASSEMBLY
24	990-070	WASHER - NYLATRON [2.EA]		51	2232350	EYELET-ROPE	*82	2263462	SCREW 1/4-20X2 SS [4.EA]
25	2068050	MOTOR ASSEMBLY 12V3.25 5SPC FW 40#		52	2261821	HINGE DOOR-PAINTED F/W	*83	2261713	WASHER-1/4 FLAT 18-18 [4.EA]
26	2032053	TUBE-COMPOSITE 42"		53	2262640	PIN-HINGE DOOR	*84	2263103	NUT- 1/4-20 NYLOC-JAM [4.EA]
■	1378122	PROPELLER KIT		54	2260183	KNOB-HINGE COVER A/T FW	*85	2301720	WASHER.MOUNTING RUBBER [6. EA]
27	2061125	PROP (65 WEEDLESS WEDGE)		55	2251600	ROPE- 31'	86	2265631	DECAL- MOTOR REST AT [2.EA]
28	2151726	WASHER-5/16 STD SS		56	2267200	LATCH LEVER			
29	2053101	NUT-PROP NYLOCK MED		57	2263800	STRAP-HOLD DOWN			
30	2092600	PIN-DRIVE (95-4HP'S) (SS)		58	2261910	BRACKET HOLD DOWN STRAP			
				59	2260500	PIN-ROLL LATCH LEVER [2.EA]			

****Seal & Oring Kit P/N 2883460**

* This item is part of an assembly. This item cannot be sold separately due to machining and /or assembly that is required.

p/n 2264952 rev. A 7-01

